

406541-1, -3, & -6
 1-406541-1, 1--3, & 1--6

406541-4
 1-406541-4
 WITHOUT LOWER
 RIGHT PANEL GROUND

- ▲ MATERIAL:
 HOUSING - HIGH TEMPERATURE THERMOPLASTIC, COLOR: BLACK, UL94V-0
 TERMINALS - 0.36[.014] THICK PHOS BRONZE PLATED WITH 3.81μm[.000150] MINIMUM THICK (SEE P/N TABLE) IN SOLDER AREA. 1.27μm[.000050] MINIMUM GOLD IN LOCALIZED PLATE AREA. ENTIRE TERMINAL PLATED WITH 1.27μm[.000050] MINIMUM THICK NICKEL.
 SHIELD - 0.196[.0077] THICK COPPER ZINC ALLOY PREPLATED WITH 1.27μm[.000050] MINIMUM SATIN NICKEL WITH 2.03μm[.000080] MINIMUM TIN POST DIPPED ON PCB GROUND TABS.
2. JACK CAVITY CONFORMS TO FCC RULES AND REGULATIONS PART 68, SUBPART F.
- ▲ SUGGESTED PANEL OPENING DIMENSIONS.
- ▲ SUGGESTED CLEARANCE BETWEEN TOP OF CONNECTOR AND TOP PANEL OPENING.
- ▲ ON 406541-4 & 1-406541-4 LOWER RIGHT HAND PANEL GROUND TAB IS NOT PRESENT.
- ▲ MANUFACTURING DATE CODE: LOCATED APPROX. AS SHOWN.
 FIRST 2 DIGITS = LAST 2 DIGITS OF YEAR.
 NEXT 2 DIGITS = MANUFACTURING WORK WEEK,
 LAST DIGIT = DAY OF WEEK WITH SUNDAY = 1.

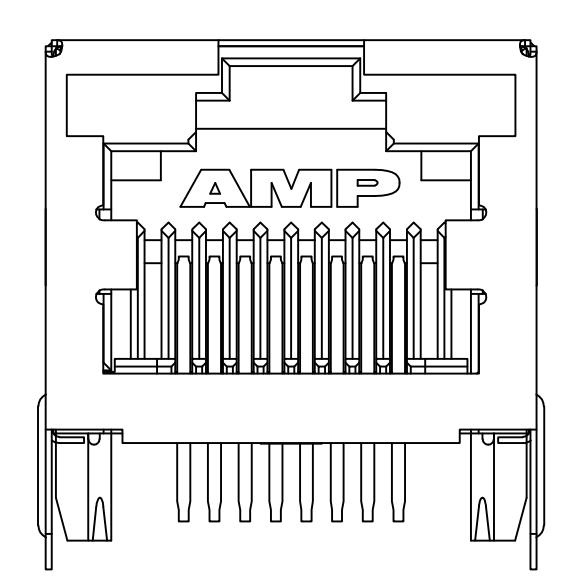

406541-5
 1-406541-5
 WITHOUT PANEL GROUNDS

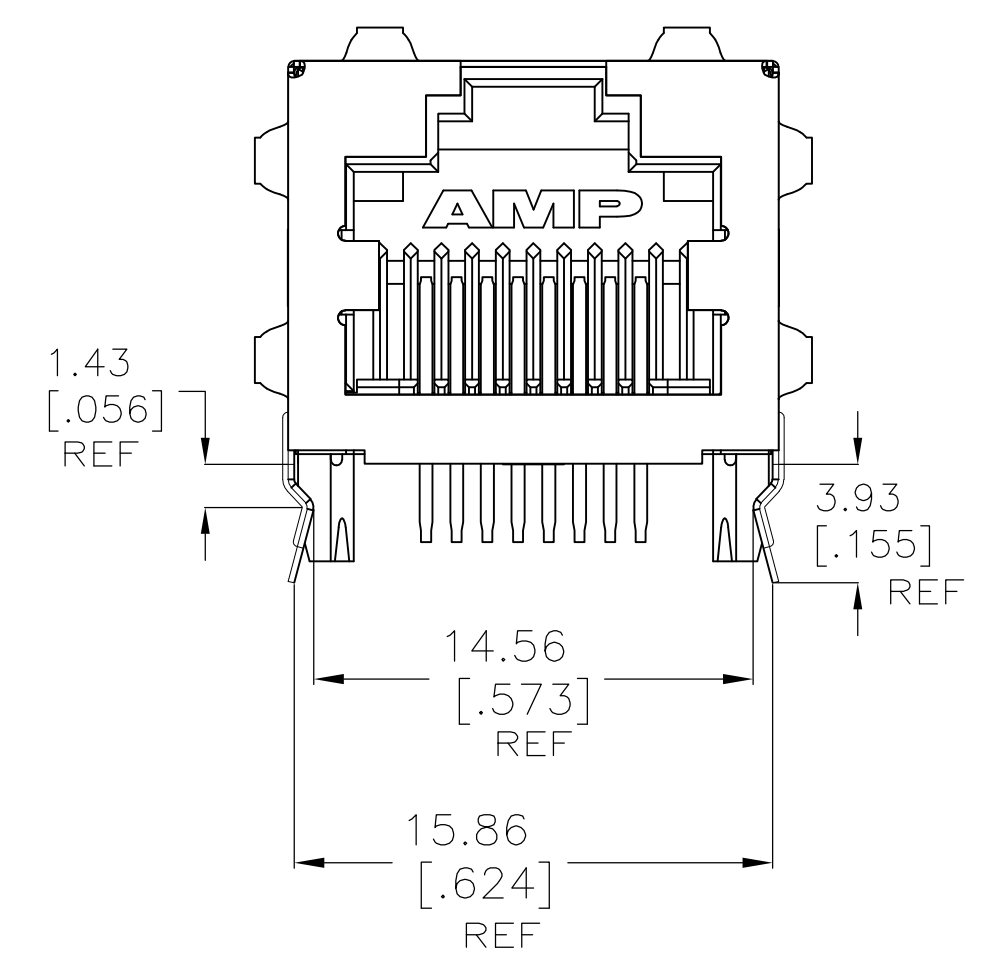

1-406541-7

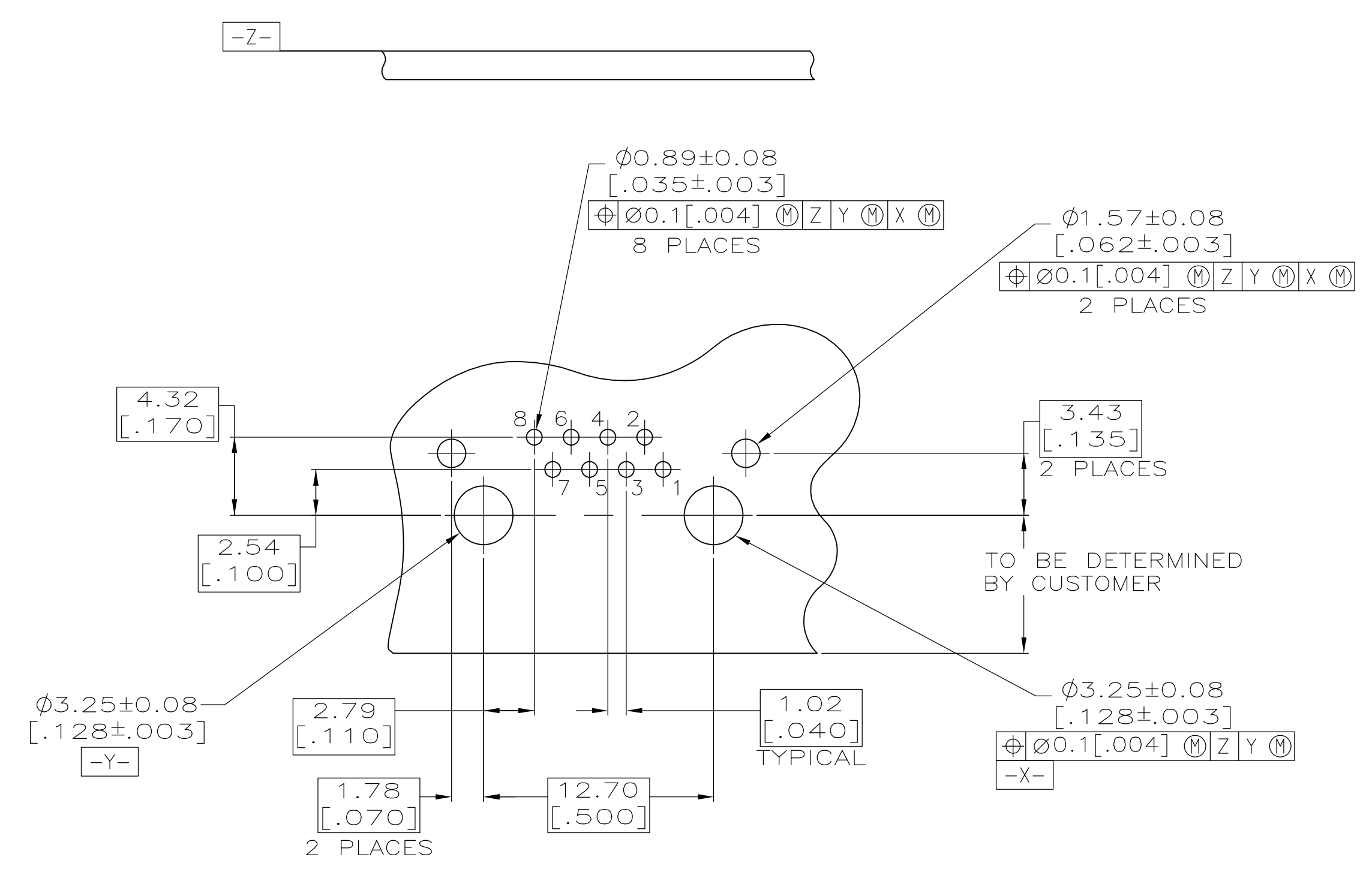

SUGGESTED PRINTED CIRCUIT BOARD LAYOUT
 (COMPONENT SIDE)

TERMINAL FINISH	PANEL GROUNDS	DIM A	PART NUMBER
MATTE TIN	6	2.54 [.100]	1-406541-7
	6	3.56 [.140]	1-406541-6
	0	2.54 [.100]	1-406541-5
	5 ▲	2.54 [.100]	1-406541-4
	6	2.00 [.079]	1-406541-3
	6	2.54 [.100]	1-406541-1
BRIGHT TIN-LEAD	6	3.56 [.140]	406541-6
	0	2.54 [.100]	406541-5
	5 ▲	2.54 [.100]	406541-4
TERMINAL PLATING ▲	6	2.00 [.079]	406541-3
	6	2.54 [.100]	406541-1

OBSELETE -3

THIS DRAWING IS A CONTROLLED DOCUMENT.

DW	TS/LA.MAYER	09JAN2008	Tyco Electronics Corporation Harrisburg, PA 17105-3608
CHK	J.WESTMAN	09JAN2008	
APRD	S.FLICKINGER	09JAN2008	INVERTED MODULAR JACK ASSEMBLY, 1 X 1, SHIELDED, PANEL GROUND
NAME			
DIMENSIONS:	TOLERANCES UNLESS OTHERWISE SPECIFIED:	PRODUCT SPEC	RESTRICTED TO
mm [INCHES]	0 PLC ± -	APPLICATION SPEC	
	1 PLC ± -		
	2 PLC ± 0.25[.010]		
	3 PLC ± -		
	4 PLC ± -		
	ANGLES ± -		
MATERIAL	FINISH	WEIGHT	SIZE CAGE CODE DRAWING NO
SEE TABLE	SEE TABLE		A1 00779 ©=406541
			CUSTOMER DRAWING

SCALE 4:1 SHEET 1 OF 1 REV L1